



ELEKTRİK - ELEKTRONİK SAN.TİC.A.Ş.



RGT-12SVC ⊕ USER MANUAL

Main Usage Areas



Banks



Hotels



Oil Stations



Schools



Malls



Factories

www.tense.com.tr

www.tenseenerji.com

Index

About RGT-12SVC	1
What is the SVC (TCR)?	1
Features	1
Warnings	2
Matters to be Considered in Power Factor Correction	2
Points to Consider in Current Transformer Selection and Connection.....	3
Maintenance of the Device	3
Quick Installation Guide	4
Measuring Screens	6
Menu Screens	7
3P4W Connection Scheme	8
Screen Description.....	9
How to Install the Device?	10
How to Change Current Transformer Value?	11
How is the Current Transformer Test Performed?	13
How is Step Measurement?	14
How to Enter Step Value Manually?	15
How is Step Control Done?	16
Measurement	
Measurement Screen Introduction	16
Total Powers Page	17
Cosinus Page	17
Ratios Page	17
Voltage and Frequency Page	17
Voltage and Current Page	17
Instant Powers Page	18
Total Energy Page	18
THD-V and THD-I page	18

Index

Settings	18
Current Transformer Menu	18
Current Transformer Test	19
Current Transformer Value	19
Step Menu	20
Step Values	20
Step Measurement	20
Step Time Settings	21
Power Factor Correction Settings	21
Step Control	22
Manual Step Value Set	22
Automatic Step Measurement Period	23
Advanced Settings Menu	23
Power Factor Correction	23
Power Analysis Samples	24
ModBus RS485 (Communication Settings)	24
Operating Power.....	25
Operating Harmonic	25
Delete Logs	26
Generator Settings.....	26
Power Factor Correction Alarm	27
Device Settings Menu	27
Factory Default	27
Change Password	28
Language Options	28
Backlight Settings	29
Capacitor Calculation Table by Connection Type	30
Step Value Determination According to Power Analysis Samples	31
Factory Defaults	32
Dimensions	33
Technical Specifications	34
Contact Informations	34

About RGT-12SVC

It is designed to reduce reactive (inductive and capacitive) power that comes from the network and loads do not use. If the inductive reactive power is attracted from the network, it interferes by attracting capacitor at the appropriate step. If capacitive reactive power is attracted from the network, interferes by attracting shunt reactor at the appropriate step. Thus it endeavors to reduce the inductive/active and capacitive/active rates of the system.

It is designed to make more sensible compensation at the unbalanced inductive and capacitive systems with RGT-12SVC TCR(SVC) step.

What is the SVC (TCR) ?

SVC is a new generation compensation system that works to minimize the capacitive power in the system by activating the reactors connected to the TCR (Thyristor Controlled Reactor) unit as much as necessary against the instantaneous capacitive power in the system.

Features

- ◆ 2.9" (128x64) Easy to install and use with graphic LCD.
- ◆ TCR (SVC) Connectable
- ◆ Generator Input and Generator Compensation
- ◆ Remote Communication with Rs485 (Computer Communication)
- ◆ Compensation for Inductive and Capacitive Systems
- ◆ Manual Step Value Enterable
- ◆ Single, Two and Three Phase Capacitor and Shunt Reactor can be connected
- ◆ Turkish and English Language Option
- ◆ Voltage, Harmonic Current/Voltage, Inductive and Capacitive Alarm Output
- ◆ Step Drive, Step Release, Discharge and Settlement Times are Adjustable
- ◆ Current Harmonics can be Observed Up To 31st Harmonics
- ◆ Voltage Harmonics can be Observed Up To 31st Harmonics
- ◆ Cosine Values of Each Phase Can Be Observed
- ◆ Power Factor Values of Each Phase can be Observed
- ◆ Capacitive/Active and Inductive/Active Ratios can be Observed
- ◆ Total Active and Reactive Energies (Import/Export/Inductive/Capacitive) can be Observed.
- ◆ THD-V and THD-I values of Each Phase can be Observed.
- ◆ Creating Power Analysis (20 samples 9999 min.)
- ◆ It Shows The Total Number of Uses of the Steps.
- ◆ Encrypted Protection
- ◆ Same Aging in Steps

Warnings

- Use the device according to our instructions.
- Avoid direct sun light in order not to harm the LCD screen.
- Leave at least 10 cm of space behind the device after mounting.
- Fix the device with apparatus which comes within the device by avoiding any kind of shake on the front cover of the board.
- Balance the inner and outer heat in the metal boards. Otherwise because of the temperature difference that originates from the dampish surrounding, water droplets occurs on the ceiling of the board and this situation is dangerous for the open connected buses.
- Mark the switch and circuit breaker as the connection tripping element for the device.
- Keep the switch and circuit breaker close to the device and easily accessible by the operator.
- There must be no electricity in the connection cables when assembling.
- Screened and twisted cord cables should be used on the input and output lines without connection to the Mains (network). These cables should not pass near high-Voltage lines and devices.

Matters to be Considered in Power Factor Correction

- Compensation starts with the regulations of the load distribution of the Electrical wiring in a balanced way that belongs to the system.
- **For the current transformer test, connect three phase capacitors in 1/40 (*) of the current transformer value to the first three stages of the device. (* : The total value of the first three levels.)**
- Do not define step number and capacitor values randomly where has rapid load changing and where huge amount of load is distributed randomly.
- You can get benefit from the examples which are in the Power Analysis, in order to compensate more effectively to the unbalanced loads in the system.
- It is advisable to add new steps at the same value for the lifespan of the commonly used step's conductor and capacitor.
- While preparing compensation board be careful about that you should easily add new steps for probable changings (load adding or excluding) that can occur subsequently.
- While making current transformer test and measurement of the step, be careful about avoiding rapid load changing on the system as much as possible.
- Choose the automatic fuse current values used in steps according to the power of the capacitor and reactor and point as connection removing member.
- Use separate automatic fuse for each feeding inductor of the step conductors.
- Use compensation contactors and discharge inductors at the steps.
- Monophase connection at the three phase systems is only appropriate for balanced load attraction. Otherwise desired rates cannot be obtained.

Points to Consider in Current Transformer Selection and Connection

- Be careful about the value of the current transformer to be more than the maximum current which could be/is attracted from the system.
- It is recommended that class of the current transformers (it can be also mentioned class, klas, kl, cl) should be 0,5 which will be used at the compensations.
- Only X5A current transformers can be connected to the RGT-12SVC.
- Be careful about the absence of any load before the current transformers. Otherwise there can be differences between reactive and counter.
- Current transformer outputs and phase inputs must be in the same order. Connect the k-l terminals of the current transformer connected to the L1 phase to the k1-l1 terminals, the k-l terminals of the current transformer connected to the L2 phase to the k2-l2 terminals and the k-l terminals of the current transformer connected to the L3 phase to the k3-l3 terminals.
- While connecting output of the current transformer terminals in order to avoid confusion, use different coloured cable for each phase or number the cables.
- Pass the cables which is connected to the output of the current transformer far from the high voltage line.
- It is advised that the cables to be used which are connected to current transformer should be minimum 1.5 mm². It is also recommended that the cables should be thickened as the distance increase.
- In order to avoid shake at the current transformers, fix to the bus, cables or rail.
- The cable distance connected to the current transformer output ends should not be kept long. Otherwise there may be errors in the measurements.
- Cable connected to current transformer output ends, one piece should be. Otherwise, measurements may have errors and current transformer testing may not be possible.

Maintenance of the Device

Turn off the energy of device and disconnect it from the connections. Clean the body of the device with a slightly damp or dry cloth. Do not use conductive or other chemicals that may damage the device as a cleaning materials. After the device is cleaned, make connections and make sure that the device is working by energizing the device.

Quick Installation Guide

Warning!

Three-phase capacitor equivalent to 1/40 of current transformer ratio must be connected in the first three steps for current transformer test to be performed. Also, the current transformer connected to the device and the phase order of the voltages must be the same. Otherwise, the device will give phase inverse or step low warning. After fixing the connection errors according to the warnings, you can start the device setup again.

1

Pressing the SET button while on any measurement page displays the PASSWORD page to enter the menu.

```
PF: 1.000   Ind(%)
P : 0.000kW  0.0
+Q: 0.000kVar
-Q: 0.000kVar   Cap(%)
S : 0.000kVA  0.0
Of f: 0.0kVar
-----
TCR % R: 23 S: 23 T: 23
```

2

While on this page, press the SET button to enter the menu.

```
Enter Password!
PASS : 0000
```

4

While in this page, press the SET button to enter the Current Transformer Value in the system.

Current Transformer Value Entry page will be displayed on the screen.

```
Menu. 1. 2
```

```
CURRENT TRANSFORMER
VALUE
```

3

While on this page, press SET button to access Current Transformer Menu.

The Current Transformer Test page will appear on the screen. Press the UP button to switch to the Current Transformer Value page.

```
Menu. 1. 0
```

```
CURRENT TRANSFORMER
MENU
```

5

While on this page, enter the Current Transformer Value in the system using the UP and DOWN buttons and then press the SET button to save.

The device will automatically start Current Transformer Test operation.

```
Menu. 1. 2. 1
Current Trans. Value

CTR: 1500 / 5A
```

6

In case of any problems in the connections, the device will give a warning and will not accept the connection.

According to the warnings, connection errors after correcting, you can start current transformer test again.

```
Current Trans. Test (A)
Please Wait!

L1: 0.000
L2: 0.000
L3: 0.000

Esc: Cancel
```

7

When current transformer test is successful, this page will be displayed on the screen.

If the operation is confirmed by pressing the SET button, the device will automatically start the Step Measurement process.

After the test, it indicates that the current transformer terminals indicated with "(-)" are connected reversely. You don't need to fix the links. The device will fix these connections software-wise.

8

During the step measurement, this page will be displayed on the screen, all steps will be measured in order and their values will be displayed on the screen.

Capacitor values are shown with "-" sign, shunt reactors are unsigned.

```

Current Trans. Test(A)
Contacts Learned
k1-l 1: (-)
k2-l 2: (+)
k3-l 3: (+)
Esc: Cancel      Set: Ok
  
```

```

Step Measure. (kVAr)
Please Wait!
1. Step      L1: - 3. 333
              L2: - 3. 333
              L3: - 3. 333
Esc: Cancel
  
```

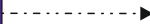

9

When the step measurement is finished, a confirmation page will be displayed on the screen. When the SET button is pressed, all the measured steps are saved and when you return to the measurements screen with the ESC button, the device starts to intervene.

Pressing the ESC button cancels the step measurements and returns to the Step Measurement page without saving.

You can check the stored step values on the Step Values screen (2.1.1) in the Step Menu.

```

Step Measure. (kVAr)

Step Values
Approved!
Please Wait!
  
```

```

Step Measure. (kVAr)
Step Meas. Finished!
TCR      L1: 3. 333
          L2: 3. 333
          L3: 3. 333
Esc: Cancel      Set: Ok
  
```

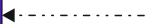

Measuring Screens

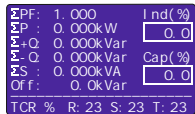

Figure-1

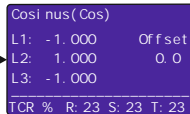

Figure-2

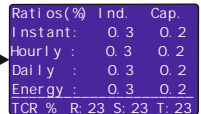

Figure-3

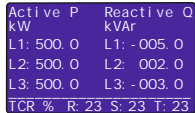

Figure-6

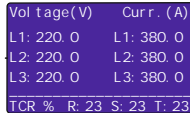

Figure-5

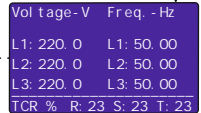

Figure-4

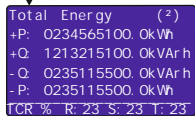

Figure-7

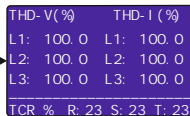

Figure-8

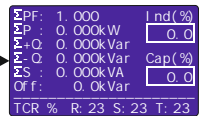

Figure-1

When the device is energized, figure-1 is displayed on the screen.
 When you press the UP button, figure-2 is displayed on the screen.
 When you press the UP button, figure-3 is displayed on the screen.
 When you press the UP button, figure-4 is displayed on the screen.
 When you press the UP button, figure-5 is displayed on the screen.
 When you press the UP button, figure-6 is displayed on the screen.
 When you press the UP button, figure-7 is displayed on the screen.
 When you press the UP button, figure-8 is displayed on the screen.
 When you press the UP button, figure-1 is displayed on the screen again.

Figure-1: Total power factor, active power, capacitive power, inductive power, apparent power, offset and active / reactive ratio values are displayed on the screen.

Figure-2: Cosine values of each phase are displayed on the screen. Pressing the RIGHT button displays the Power Factor values.

Figure-3: Instant, hourly, daily and total active consumption / reactive consumption rates are displayed on the screen.

Figure-4: Phase-Neutral voltage and frequency values are displayed on the screen. When the RIGHT button is pressed, phase-phase voltage values are displayed.

Figure-5: Phase-Neutral voltage and current values are displayed on the screen.

Figure-6: Instantaneous power values of each phase are displayed on the screen. Pressing the RIGHT button displays the Apparent Power values.

Figure-7: Total energy values are displayed on the screen. Active Energy, Inductive Energy, Capacitive Energy, Export Active Energy and Apparent Energy values are displayed respectively by pressing the RIGHT button.

Figure-8: THD-V and THD-I values are displayed on the screen. When pressing the RIGHT button, Voltage Harmonic (L1, L2, L3) and Current Harmonic (L1, L2, L3) values are shown respectively.

Menu Screens

ΣPF: 1.000	Ind(%)
ΣP: 0.000kW	0.0
Σ+Q: 0.000kVar	Cap(%)
Σ- Q: 0.000kVar	0.0
ΣS: 0.000kVA	
Of f: 0.0kVar	
TCR % R: 23 S: 23 T: 23	

Figure-1

Enter Password!
PASS : 0000

Figure-2

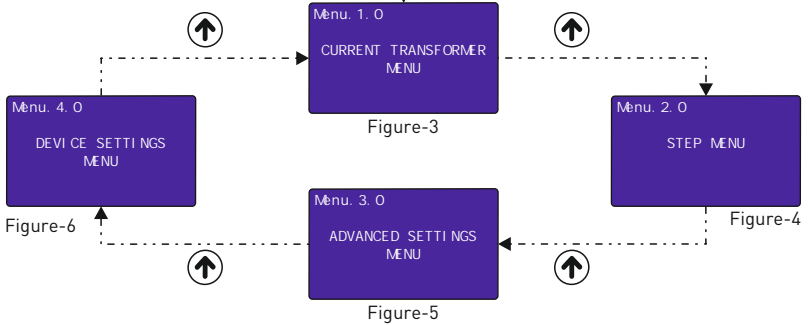

Entering Settings: When SET button is pressed on any measurement page, the PASSWORD page (Figure-2) is displayed for entering the menu.

While on this page, press the SET button to enter the menu.

(The password value is "0000" by default. If the password has been changed by the user, the password determined by the user must be used to enter the menu.)

Current Transformer Menu: It is the first menu that appears after entering the settings page (Figure-3). In this menu, you can change the current transformer value and have a current transformer test done.

Step Menu: It is the second menu that appears when you proceed by pressing the UP button after entering the settings page (Figure-4). In this menu, you can see Step Values, take Step Measurement, change Step Time Settings, make PFC settings, Make Step Control, Manually Enter Step Value and set Auto Step Measurement Period.

Advanced Settings Menu: It is the third menu that appears when you proceed by pressing the UP button after entering the settings page (Figure-5). In this menu, Compensation Target Value can be set, Power Analysis Samples can be viewed, ModBus Communication settings can be made, Operating Voltage and Operating Harmonics can be set, Logs can be deleted, Generator Compensation and Compensation Alarm settings can be made.

Device Settings Menu: It is the fourth menu that appears when you proceed by pressing the UP button after entering the settings page (Figure-6). In this menu, Factory Settings can be changed, Password and Device Language can be changed, and the duration of the Backlight can be adjusted.

3P4W Connection Scheme

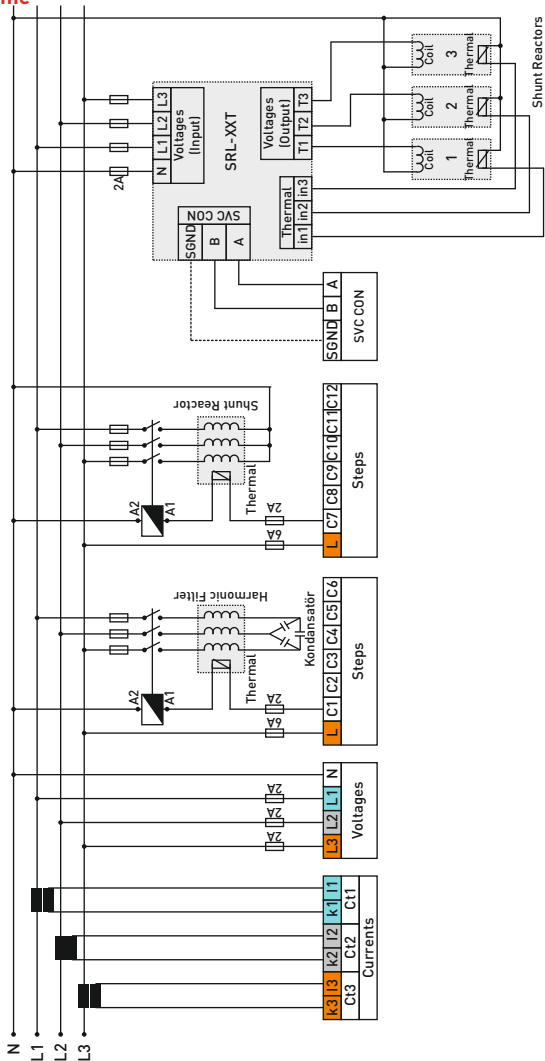



1- Stage Leds: The LEDs are lit when the steps are active.

2- Alarm Led: It is the LED that lights to alert the user in case of alarm.

3- Graphic LCD: It is the screen where all measurements, settings and notifications related to the device are transferred to the user.

4- Status Leds: Reactive/Active instant rate status and communication notification leds.

COM Led (Communication): This LED is on during ModBus RTU communication.

IND Led (Inductive): This LED will light if the inductive/active instantaneous rate is more than 20%.

NOR Led (Normal): Inductive/Active instantaneous rate less than 20% and Capacitive/Active instantaneous rate less than 15% If it is low, this led will light.

CAP Led (Capacitive): If the capacitive/active instantaneous rate is more than 15%, this led will light.

4- Buttons: They are used to monitor measurements and make adjustments.

ESC Button: When pressed in the menu, it returns to the upper menu without saving the values. When pressed outside the menu (on the measurement screens), always displays the Main measurement screen.

SET Button: Enters the menu/parameter. By saving the change in the parameter exits the parameter.

UP Button: It provides fast progress between the measured values outside the menu. Increases the selected value while inside the parameters of the menu.

DOWN Button: It provides fast progress between the measured values outside the menu. Decreases the selected value while inside the parameters of the menu.

RIGHT Button: When out of the menu, it provides the progress between the measurement values by showing the measured values together with the details. It enables to switch between parameters while in the menu.

How to Install the Device?

Enter Password!
PASS : 0000

Three-phase capacitor equivalent to 1/40 of current transformer ratio must be connected in the first three steps for current transformer test to be performed. Also, the current transformer connected to the device and the phase order of the voltages must be the same. Otherwise, the device will give phase inverse or step low warning. After fixing the connection errors according to the warnings, you can start the device setup again.

When SET button is pressed on any measurement page, the PASSWORD page is displayed for entering the menu.

Menu. 1. 0

CURRENT TRANSFORMER
MENU

While on this page, press the SET button to enter the menu.

[The password value is "0000" by default. If the password has been changed by the user, the password determined by the user must be used to enter the menu.]

Menu. 1. 2

CURRENT TRANSFORMER
VALUE

After passing the password page, Current Transformer Menu page will be displayed on the screen.

While on this page, press SET button to enter Current Transformer Menu.

The Current Transformer Test page will appear on the screen. Press the UP button to switch to the Current Transformer Value page.

Menu. 1. 2. 1

Current Trans. Value

CTR: 1500 / 5A

While in this page, press the SET button to enter the Current Transformer Value in the system.

Current Transformer Value Entry page will be displayed on the screen.

Current Trans. Test(A)
Please Wait!

L1: 0.000
1. Trial L2: 0.000
L3: 0.000

Esc: Cancel

The device will automatically start Current Transformer Test operation.

In case of any problems in the connections, the device will give a warning and will not accept the connection.

When current transformer test is successful, this page will be displayed on the screen.

If the operation is confirmed by pressing the SET button, the device will automatically start the Step Measurement process.

Current Trans. Test(A)
Contact Learned

k1-l 1: (-)
k2-l 2: (+)
k3-l 3: (+)

Esc: Cancel

Set: OK

After the test, it indicates that the current transformer terminals indicated with "[-]" are connected reversely. You don't need to fix the links. The device will fix these connections software-wise.

Step Measure. (kVAR)
Please Wait!
L1: - 3.333
L2: - 3.333
L3: - 3.333
1. Step
Esc: Cancel

During the step measurement, this page will be displayed on the screen, all steps will be measured in order and their values will be displayed on the screen.

Capacitor values are shown with a "-" sign and shunt reactors are unsigned.

Step Measure. (kVAR)
Step Meas. Finished!
L1: 3.333
L2: 3.333
L3: 3.333
TCR
Esc: Cancel Set: OK

When the stage measurement is finished, a confirmation page will be displayed on the screen. When the SET button is pressed, all measured steps are saved and the device starts to intervene.

Pressing the ESC button cancels the step measurements and returns to the Step Measurement page without saving.

You can check the stored step values on the Step Values screen (2.1.1) in the Step Menu.

How to Change Current Transformer Value?

Enter Password!
PASS : 0000

Three-phase capacitor equivalent to 1/40 of current transformer ratio must be connected in the first three steps for current transformer test to be performed. Also, the current transformer connected to the device and the phase order of the voltages must be the same. Otherwise, the device will give phase inverse or step low warning. After fixing the connection errors according to the warnings, you can start the device setup again.

When SET button is pressed on any measurement page, the PASSWORD page is displayed for entering the menu.

While on this page, press the SET button to enter the menu.

(The password value is "0000" by default. If the password has been changed by the user, the password determined by the user must be used to enter the menu.)

Menu. 1. 0

CURRENT TRANSFORMER
MENU

After passing the password page, Current Transformer Menu page will be displayed on the screen.

While on this page, press SET button to enter Current Transformer Menu.

The Current Transformer Test page will appear on the screen. Press the UP button to switch to the Current Transformer Value page.

Menu. 1. 2

CURRENT TRANSFORMER
VALUE

Menu. 1. 2. 1
Current Trans. Value
CTR: 1500 / 5A

While in this page, press the SET button to enter the Current Transformer Value in the system.

Current Transformer Value Entry page will be displayed on the screen.

While on this page, use the UP and DOWN buttons to enter the Current Transformer Value in the system and then press the SET button to save.

The device will automatically start Current Transformer Test operation.

In case of any problems in the connections, the device will give a warning and will not accept the connection.

When current transformer test is successful, this page will be displayed on the screen.

If the operation is confirmed by pressing the SET button, the device will automatically start the Step Measurement process.

After the test, it indicates that the current transformer terminals indicated with “[-]” are connected reversely. You don’t need to fix the links. The device will fix these connections software-wise.

Current Trans. Test(A)
Please Wait!
L1: 0.000
L2: 0.000
L3: 0.000
1. Trial
Esc: Cancel

Current Trans. Test(A)
Contact Learned
k1-l1: (-)
k2-l2: (+)
k3-l3: (+)
Esc: Cancel Set: OK

Step Measure. (kVAr)
Please Wait!
L1: -3.333
L2: -3.333
L3: -3.333
1. Step
Esc: Cancel

During the step measurement, this page will be displayed on the screen, all steps will be measured in order and their values will be displayed on the screen.

Capacitor values are shown with a “-” sign and shunt reactors are unsigned.

When the stage measurement is finished, a confirmation page will be displayed on the screen. When the SET button is pressed, all measured steps are saved and the device starts to intervene.

Pressing the ESC button cancels the step measurements and returns to the Step Measurement page without saving.

You can check the stored step values on the Step Values screen (2.1.1) in the Step Menu.

Step Measure. (kVAr)
Step Meas. Finished!
L1: 3.333
L2: 3.333
L3: 3.333
TCR
Esc: Cancel Set: OK

How is the Current Transformer Test Performed?

Enter Password!
PASS : 0000

Three-phase capacitor equivalent to 1/40 of current transformer ratio must be connected in the first three steps for current transformer test to be performed. Also, the current transformer connected to the device and the phase order of the voltages must be the same. Otherwise, the device will give phase inverse or step low warning. After fixing the connection errors according to the warnings, you can start the device setup again.

Menu. 1. 0

CURRENT TRANSFORMER
MENU

When SET button is pressed on any measurement page, the PASSWORD page is displayed for entering the menu.

While on this page, press the SET button to enter the menu.

(The password value is "0000" by default. If the password has been changed by the user, the password determined by the user must be used to enter the menu.)

Menu. 1. 1

CURRENT TRANSFORMER
TEST

After passing the password page, Current Transformer Menu page will be displayed on the screen.

While on this page, press the SET button to enter the Current Test Menu.

Menu. 1. 1. 1

Current Trans. Test

Yes : [*]
No : []

While on this page, press SET button to enter Current Transformer Test confirmation page.

When you press the SET button on this page, the device will automatically start Current Transformer Test operation.

Current Trans. Test(A)
Please Wait!

1. Trial L1: 0.000
L2: 0.000
L3: 0.000
Esc: Cancel

In case of any problems in the connections, the device will give a warning and will not accept the connection.

When current transformer test is successful, this page will be displayed on the screen.

Current Trans. Test(A)
Contact Learned

k1-l 1: (-)
k2-l 2: (+)
k3-l 3: (+)
Esc: Cancel Set: OK

If the operation is confirmed by pressing the SET button, the device will automatically start the Step Measurement process.

After the test, it indicates that the current transformer terminals indicated with "[-]" are connected reversely. You don't need to fix the links. The device will fix these connections software-wise.

How is Step Measurement?

Enter Password!
PASS : 0000

When SET button is pressed on any measurement page, the PASSWORD page is displayed for entering the menu.

While on this page, press the SET button to enter the menu.

[The password value is "0000" by default. If the password has been changed by the user, the password determined by the user must be used to enter the menu.]

Menu. 2. 0

STEP MENU

After passing the password page, Current Transformer Menu page will be displayed on the screen.

While on this page, press UP button to switch to the Step Menu page.

The Step Menu page will appear on the screen. Press the SET button to enter the Step Menu page.

Menu. 2. 2

STEP MEASUREMENT

When you enter the Step Menu page, the Step Values page is displayed on the screen first.

Switch to the Step Measurement page by pressing the UP button, then enter the Step Measurement page by pressing the SET button.

Menu. 2. 2. 1 Measure.

01[*] < 05[] 09[]
02[] 06[] 10[]
03[] 07[] 11[]
04[] 08[] 12[]
TCR[] ALL[]

In this page, you can navigate between the steps with UP / DOWN buttons, after selecting the steps you want to measure with the RIGHT button, you can start the measurement process by pressing the SET button.

ALL is used to select all the steps and TCR is used to measure shunt reactors connected to the drive.

Step Measure (kVAr)

Please Wait!

1. Step L1: - 3. 333
L2: - 3. 333
L3: - 3. 333
Esc: Cancel

After the selected steps are measured, the step number and the kVAr value of the measured step are displayed on the screen.

Capacitor values are shown with a "-" sign and shunt reactors are unsigned.

After the step measurement is finished, it will say "Step Measurement Finished" on the screen.

Step Measure. (kVAr)

Step Values
Approved!
Please Wait!

When there is a "Step Measurement Finished" warning on the screen, when the SET button is pressed, the device saves the measured steps. When the ESC button is pressed, it returns to the Step Measurement page without saving the measured steps.

How to Enter the Step Value Manually?

Enter Password!
PASS : 0000

When SET button is pressed on any measurement page, the PASSWORD page is displayed for entering the menu.

While on this page, press the SET button to enter the menu.

(The password value is "0000" by default. If the password has been changed by the user, the password determined by the user must be used to enter the menu.)

Menu. 2. 0

STEP MENU

After passing the password page, Current Transformer Menu page will be displayed on the screen.

While on this page, press UP button to switch to the Step Menu page.

The Step Menu page will appear on the screen. Press the SET button to enter the Step Menu page.

Menu. 2. 6

MANUAL STEP
VALUE SET

When you enter the Step Menu page, the Step Values page is displayed on the screen first.

Switch to the Manual Step Value Set page by pressing the UP button, then enter the Manual Step Value Set page by pressing the SET button.

Menu. 2. 6. 1

Enter Step Value

>Step : 1
Type : L123
Value : -10.00kvar

In this page, you can navigate between parameters (Step, Type and Value) with the RIGHT button, and change the value in the selected parameter with the UP/DOWN buttons.

To change the current value, the relevant parameter must be selected with the RIGHT button. The selected parameter is indicated by the sign ">" on the left side.

Menu. 2. 6. 1

Enter Step Value

>Step : 1
Type : L123
Value : -10.00kvar
Step Approved

After entering the step information manually, SET button is pressed to save. After the saving process, the step information recorded and "Step Approved" are displayed on the screen.

To exit without saving, pressing the ESC button will return to the Manual Step Value Set page.

Example: On the screen above, the three-phase 10kVAr capacitor value has been entered in the 1st step.

If the value to be entered is single phase, "L1, L2 or L3" should be selected from the phase part according to the phase to which it is connected. If the value to be entered is two phase, "L12, L23 or L31" should be selected from the phase part according to the phase to which it is connected. If the value to be entered is three phase, "L123" should be selected.

Note: Capacitor values are entered as (-) signed with DOWN button. Shunt reactor values are entered unsigned with the UP button.

How is Step Control Done?

Enter Password!
PASS : 0000

It is a menu designed to control the connections and robustness of the shunt reactors, capacitors and contactors connected to the stages.

When SET button is pressed on any measurement page, the PASSWORD page is displayed for entering the menu.

While on this page, press the SET button to enter the menu.

(The password value is "0000" by default. If the password has been changed by the user, the password determined by the user must be used to enter the menu.)

After passing the password page, Current Transformer Menu page will be displayed on the screen.

While on this page, press UP button to switch to the Step Menu page.

The Step Menu page will appear on the screen. Press the SET button to enter the Step Menu page.

When you enter the Step Menu page, the Step Values page is displayed on the screen first.

Switch to the Step Control page by pressing the UP button, then enter the Step Control page by pressing the SET button.

In this page, you can navigate between the steps with UP / DOWN buttons, you can use the RIGHT button to control / activate the steps and passive the active steps.

Active steps are indicated by the "*" sign.

When you return to the measurements screen by pressing the ESC button, if there are any steps you have activated manually, the device will make these steps passive one by one.

Menu. 2. 0

STEP MENU

Menu. 2. 5

STEP CONTROL

Menu. 2. 5. 1 Control

>01[*]	05[]	09[]
02[]	06[]	10[]
03[]	07[]	11[]
04[]	08[]	12[]
TCR[]		

Measurements Measurement Screen Introduction

1- The area where the name and unit of the measured value are specified.

2- The area where the measured values are displayed.

3- The area where the SVC (TCR) usage percentage and Alarm states are displayed.

NOTE.: While the generator in the system is activated, "GEN" * will appear on the screen instead of "TCR". (*: It is valid when the generator is connected to the device.)

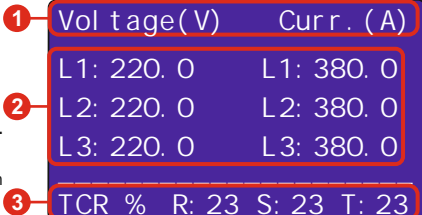

Voltage (V)		Curr. (A)	
L1: 220. 0	L1: 380. 0		
L2: 220. 0	L2: 380. 0		
L3: 220. 0	L3: 380. 0		
TCR % R: 23 S: 23 T: 23			

While on any measurement screen, you can switch to other measurement screens by using UP / DOWN or RIGHT buttons.

Measurements ◀ Total Powers Page

Σ PF:	1.000	Ind (%)	0.0
Σ P:	0.000kW		
Σ +Q:	0.000kVar	Cap (%)	0.0
Σ -Q:	0.000kVar		
Σ S:	0.000kVA		
Off:	0.0kVar		
TCR % R: 23 S: 23 T: 23			

This page shows the total instantaneous powers (power factor, active power, capacitive power, inductive power, apparent power) values, the offset value defined in the device and the reactive ratios.

When RIGHT or UP button is pressed on this page, Cosinus page is displayed. When DOWN button is pressed, THDV and THDI page is displayed. When the SET button is pressed, the password page is displayed for entering the menu.

Measurements ◀ Cosinus Page

Cosinus (Cos)	
L1:	-1.000 Offset
L2:	1.000 0.0
L3:	-1.000
TCR % R: 23 S: 23 T: 23	

This page shows the Cosinus values for each phase.

When RIGH button is pressed on this page, Power Factor page is displayed. When UP button is pressed, Ratios page is displayed. When DOWN button is pressed, Total Power page is displayed. When the SET button is pressed, the password page is displayed for entering the menu.

Measurements ◀ Ratios Page

Ratios (%)	Ind.	Cap.
Instant:	0.3	0.2
Hourly :	0.3	0.2
Daily :	0.3	0.2
Energy :	0.3	0.2
TCR % R: 23 S: 23 T: 23		

This page shows the Instantaneous, Hourly, Daily and Total Inductive / Active and Capacitive / Active Ratios.

NOTE: The device clears hourly and daily ratios after power failure and starts recalculating.

When RIGHT or UP button is pressed on this page, Voltage (L-N) & Frequency page is displayed. When DOWN button is pressed, Cosinus page is displayed. When the SET button is pressed, the password page is displayed for entering the menu. When ESC button is pressed, Home Page (Total Powers) is displayed.

Measurements ◀ Voltage and Frequency Page

Voltage-V	Freq-Hz
L1: 220.0	L1: 50.00
L2: 220.0	L2: 50.00
L3: 220.0	L3: 50.00
TCR % R: 23 S: 23 T: 23	

This page shows the voltage and frequency values between phase and neutral.

When RIGHT button is pressed on this page, Voltage (L-N) & Voltage (L-L) page is displayed. When UP button is pressed, Voltage (L-N) & Current page is displayed. When DOWN button is pressed, Ratios page is displayed. When the SET button is pressed, the password page is displayed for entering the menu. When ESC button is pressed, Home Page (Total Powers) is displayed.

Measurements ◀ Voltage and Current Page

Voltage(V)	Curr. (A)
L1: 220.0	L1: 380.0
L2: 220.0	L2: 380.0
L3: 220.0	L3: 380.0
TCR % R: 23 S: 23 T: 23	

This page shows the voltage and current values between phase and neutral.

When RIGHT or UP button is pressed on this page, Instant Powers page is displayed. When DOWN button is pressed, Voltage (L-N) & Frequency page is displayed. When the SET button is pressed, the password page is displayed for entering the menu. When ESC button is pressed, Home Page (Total Powers) is displayed.

Measurements ◀ Instant Powers Page

Active P kW	Reactive Q kVAr
L1: 500.0	L1: -005.0
L2: 500.0	L2: 002.0
L3: 500.0	L3: -003.0
TCR % R: 23 S: 23 T: 23	

This page shows the Instantaneous Power (Active and Reactive) values for each phase.

When RIGHT button is pressed on this page, Apparent Powers page is displayed. When UP button is pressed, Total Energy page is displayed. When DOWN button is pressed, Voltage (L-N) & Current page is displayed. When the SET button is pressed, the password page is displayed for entering the menu. When ESC button is pressed, Home Page (Total Powers) is displayed.

Measurements ◀ Total Energy Page

Total Energy (²)	
+P: 0234565100.0 kWh	
+Q: 1213215100.0 kVAr h	
-Q: 0235115500.0 kVAr h	
-P: 0235115500.0 kWh	
TCR % R: 23 S: 23 T: 23	

Total Energy values are displayed on this page.

If you proceed by pressing the RIGHT button while on this page, Import Active Energy, Inductive Energy, Capacitive Energy, Export Active Energy and Apparen Energy pages are displayed on the screen respectively. When UP button is pressed, THD-V and THD-I is displayed. When DOWN button is pressed, Instant Power page is displayed. When the SET button is pressed, the password page is displayed for entering the menu. When ESC button is pressed, Home Page (Total Powers) is displayed.

Measurements ◀ THD-V and TDH-I Page

THD-V (%)	THD-I (%)
L1: 100.0	L1: 100.0
L2: 100.0	L2: 100.0
L3: 100.0	L3: 100.0
TCR % R: 23 S: 23 T: 23	

This page shows THD-V and THD-I values.

If you proceed by pressing the RIGHT button while on this page, Voltage Harmonic (L1, L2, L3) and Current Harmonic (L1, L2, L3) pages are displayed on the screen respectively.. When UP button is pressed on this page, Home Page (Total Powers) page is displayed. When DOWN button is pressed, Total Energy page is displayed. When the SET button is pressed, the password page is displayed for entering the menu. When ESC button is pressed, Home Page (Total Powers) is displayed.

Settings ◀ Current Transformer Menu

Menu. 1. 0
CURRENT TRANSFORMER MENU

It is the first menu that appears after entering the settings page. In this menu, you can change the current transformer value and have a current transformer test done.

To enter the Current Transformer Menu, press the SET button while there is Current Transformer Menu page on the screen. Use UP and DOWN buttons to access other settings in the menu.

Menu. 1. 1

CURRENT TRANSFORMER
TEST

Menu. 1. 1. 1

Current Trans. Test

Yes : [*]

No : []

Current Trans. Test (A)

Contact Learned!

k1-l 1: (-)

k2-l 2: (+)

k3-l 3: (+)

Esc: Cancel

Set: OK

It is the first of two different setting parameters in the current transformer menu. To start the current transformer test, press the SET button with the Current Transformer Test page on the screen, then select Yes and press the SET button again.

Then the device will start current transformer test by pulling the first 3 steps. In case of any problems in the connections, the device will give a warning and will not accept the connection.

Three-phase capacitor equivalent to 1/40 of current transformer ratio must be connected in the first three steps for current transformer test to be performed. Also, the current transformer connected to the device and the phase order of the voltages must be the same. Otherwise, the device will give phase inverse or step low warning. After fixing the connection errors according to the warnings, you can start the device setup again.

When the current transformer test is successful, a confirmation page will appear on the screen with the words "Connection Learned".

If the operation is confirmed by pressing the SET button, the device will automatically start the Step Measurement process.

After the test, it indicates that the current transformer terminals indicated with "(-)" are connected reversely. You don't need to fix the links. The device will fix these connections software-wise.

Menu. 1. 2

CURRENT TRANSFORMER
VALUE

Menu. 1. 2. 1

Current Trans. Value

CTR: 1500 / 5A

It is the second of two different setting parameters in the current transformer menu. To change the current transformer value, press the SET button with the Current Transformer Value page on the screen, then enter the current transformer value in your system using the UP and DOWN buttons and press the SET button again to save.

The device will automatically start the current transformer test for the changed current transformer value. You can review Page 10 and (How to Install the Device) Page 11 (How to Change Current Transformer Value) for detailed explanation, .

Menu. 2. 0

STEP MENU

It is the second menu that appears when you proceed by pressing the UP button after entering the settings page. In this menu, you can see Step Values, take Step Measurement, change Step Time Settings, make PFC settings, Make Step Control, Manually Enter Step Value and set Auto Step Measurement Period.

Press the SET button while there is Step Menu page on the screen to enter the Step Menu. Use UP and DOWN buttons to access other settings in the menu.

Menu. 2. 1

STEP VALUES

Menu. 2. 1. 1

1. Kademe L123

L1: -100.00 kVAr

L2: -100.00 kVAr

L3: -100.00 kVAr

Usage Number : 10000

It is the first of 7 different setting parameters in the step menu. For the step values, press the SET button with the Step Values page on the screen.

Example: The connection status of the 1st stage, its kVAr value in each phase and the number of uses are displayed on the screen. You can navigate between values by using UP and DOWN buttons to see other step values.

Menu. 2. 2

STEP MEASUREMENT

Menu. 2. 2. 1 Measure.

01[*] < 05[] 09[]

02[] 06[] 10[]

03[] 07[] 11[]

04[] 08[] 12[]

TCR[] ALL[]

It is the second of 7 different setting parameters in the step menu. To take a step measurement, press the SET button while the Step Measurement page is on the screen.

In this page, you can navigate between the steps with UP / DOWN buttons, select the steps you want to measure with the RIGHT button and start the measurement process by pressing the SET button.

The stages selected for the measurement are displayed with the "*" sign.

You can review Page 14 (How is Step Measurement?) for detailed explanation.

Menu. 2. 3

STEP TIME
SETTINGS

Menu. 2. 3. 1

Step Times
>Drive : 3 sec.
Release : 2 sec.
Discharge: 15 sec.
Setting : 400 msec.

It is the third of 7 different setting parameters in the step menu. To change the Step Time Settings, press the SET button while the Step Time Settings page is on the screen. To change the current value, the relevant parameter must be selected with the RIGHT button. The selected parameter is indicated by the ">" sign on the left side.

Then the selected value can be changed with UP / DOWN buttons. The changed value is saved by pressing the SET button.

Drive Time: It determines the activation time of the step to intervene in the power change in the system.

Factory Setting = 2.0sec. , Setting Range: 1sec. – 30sec.

Release Time: It determines the time for releasing the step that is activated to interfere with the power change in the system.

Factory Setting = 2.0sec. , Setting Range: 1sec. – 30sec.

Discharge Time: It determines the duration of the capacitor discharge (being able to reactivate the same stage).

Factory Setting = 15sec. , Setting Range: 1sec. – 60sec.

Settling Time: When the device needs to activate several steps at once, it determines the time to wait between the steps.

Factory Setting = 400msec. , Setting Range: 100msec. – 3000msec.

Menu. 2. 4

PFC SETTINGS

Menu. 2. 4. 1

PFC Settings
>PFC : Active
TCR : Active
Offset: -10.0 kVar

It is the fourth of 7 different setting parameters in the step menu. To change the PFC Settings, press the SET button while the PFC Settings page is on the screen.

To change the current value, the relevant parameter must be selected with the RIGHT button. The selected parameter is indicated by the ">" sign on the left side.

PFC: It enables/disables the device's intervention to reactive powers in the system with capacitors and shunt reactors. When PFC is disabled, the device does not activate steps.

TCR: Activates/deactivates the device's intervention to reactive powers in the system with an inductive load driver (if the system has an inductive load driver). When TCR is passive, the device will not activate the inductive load driver.

Offset: It is the value used for reactive powers between the electricity meter and the reactive relay that the reactive relay cannot measure. This value that the device cannot measure is calculated software and intervened accordingly.

Example: If offset is entered as -10kVAR, it means that there is a three-phase 10kVAR capacitive power that the reactive relay cannot measure. The reactive relay will interfere with this power, in addition to the target cosine value, with three-phase 10kVAR inductive power. (If offset capacitive (-) is entered, the power to be applied becomes inductive (+), If offset inductive (+) is entered, the power to be applied becomes capacitive (-).)

Settings Step Menu Step Control

Mnu. 2. 5

STEP CONTROL

Mnu. 2. 5. 1 Control

>01[*] 05[] 09[]
02[] 06[] 10[]
03[] 07[] 11[]
04[] 08[] 12[]
TCR[]

It is the fifth of the 7 different setting parameters in the step menu. To perform the Step Check, press the SET button while the Step Check page is on the screen.

You can navigate between the levels with UP/DOWN buttons, you can use the RIGHT button to control/activate/deactivate the steps and to deactivate the active steps.

When you return to the measurements screen by pressing the ESC button, the device will inactivate these stages one by one if there are activated stages.

Settings Step Menu Manual Step Value Set

Mnu. 2. 6

MANUAL STEP
VALUE SET

Mnu. 2. 6. 1

Enter Step Value
>Step : 1
Type : L123
Value : -10.00kVAR

Mnu. 2. 6. 1

Enter Step Value
>Step : 1
Type : L123
Value : -10.00kVAR
Step Approved

It is the sixth of the 7 different setting parameters in the step menu. To enter the manual step value, press the SET button while the Manual Step Value Enter page is on the screen.

In this page, you can navigate between parameters (Step, Type and Value) with the RIGHT button, and change the value in the selected parameter with the UP / DOWN buttons.

To change the current value, the relevant parameter must be selected with the RIGHT button. The selected parameter is indicated by the ">" sign on the left side.

After entering the step information manually, SET button is pressed to save. The step information recorded after the saving process and the "Step Approved" notification appear on the screen.

To exit without saving, pressing the ESC button will return to the Manual Step Value Set page.
Example: On the screen above, the three-phase 10kVAR capacitor value has been entered in the 1st step.

If the value to be entered is single phase, "L1, L2 or L3" should be selected from the phase part according to the phase to which it is connected. If the value to be entered is two phase, "L12, L23 or L31" should be selected from the phase part according to the phase to which it is connected. If the value to be entered is three phase, "L123" should be selected.

Note: Capacitor values are entered as (-) signed with DOWN button. Shunt reactor values are entered unsigned with the UP button.

Settings Step Menu Automatic Step Measurement Period

Menu. 2. 7

AUTOMATIC STEP
MEASUREMENT PERIOD

Menu. 2. 7. 1

Step Measure. Period

Period : 0 Week

Period Passive

The capacitors connected at the stages experience a decrease in their capacities depending on the frequency of use and time. With this parameter, it is aimed that the current values of the capacitors can be learned by the device at certain time intervals and the device can intervene more precisely.

At the end of the set period, the device will automatically measure and record all steps in the system and perform its intervention according to the current step values.

It is the seventh of 7 different setting parameters in the step values menu. To change the Automatic Step Measurement Period, press the SET button while the Automatic Step Measurement Period page is on the screen.

You can use UP / DOWN buttons to change the current value. Press the SET button to save.

Settings Advanced Settings Menu

Menu. 3. 0

ADVANCED SETTINGS
MENU

It is the third menu that appears when you proceed by pressing the UP button after entering the settings page. In this menu, Compensation Target Value can be set, Power Analysis Samples can be viewed, ModBus Communication settings can be made, Operating Voltage and Working Harmonics can be set, Records can be deleted, Generator Compensation and Compensation Alarm settings can be made.

To enter the Advanced Settings Menu, press the SET button while the Advanced Settings Menu page is on the screen. Use UP and DOWN buttons to access other settings in the menu.

Settings Advanced Settings Menu Power Factor Correction

Menu. 3. 1

POWER FACTOR
CORRECTION

Menu. 3. 1. 1

PF Correction

>Set : 5%

Tolerance: % 1. 0

Cos: 0. 9988 Induct.

It is the first of the 8 different setting parameters in the advanced settings menu. To change the Power Factor Correction Settings, press the SET button with the Power Factor Correction page on the screen.

To change the current value, the relevant parameter must be selected with the RIGHT button. The selected parameter is indicated by the ">" sign on the left side.

Set: The targeted compensation set value is entered here. Inductive or Capacitive set can be entered. The Cosinus value that will occur as a result of the entered set value appears at the bottom of the screen.

Tolerance: It is the movement area that will be given to the device in an inductive and capacitive direction in order to ensure less activation / passivation to extend the lifetime of the contactors, capacitors and reactors in the stages. The device will not change its current response for reactive power changes within the SET \pm Tolerance value in this field.

Example: If the SET value is 0% (Cos: 1) and the Tolerance value is 2%, the device will not change its current response for reactive power changes within this area after reaching a ratio between Inductive 2% and Capacitive 2%.

Settings Advanced Settings Menu Power Analysis Samples

Mènu. 3. 2

POWER ANALYSYS
SAMPLES

Mènu. 3. 2. 1

SAMPLE: 1

L1: -100.00 kVAr

L2: -100.00 kVAr

L3: -100.00 kVAr

Sampl e Ti m e: 10000 m i n

It is the second of 8 different setting parameters in the advanced settings menu. To view the Power Analysis Samples, press the SET button while the Power Analysis Samples page is on the screen.

In this page, reactive powers drawn from each phase are recorded along with their duration. (capacitive powers are indicated by a (-) sign.)

If the power consumption remains constant over a certain period of time, it is recorded as an sample. If the next sample is 15% above the previous one, it will be saved as a different one. If the under 15%, only the duration is added to the previous example. Contains a total of 20 samples. It can take samples for up to 9999 minutes.

You can use the UP / DOWN buttons to navigate through the samples.

You can review Page 31 for detailed explanation. (Step Value Determination According to Power Analysis Examples.)

Settings Advanced Settings Menu ModBus RS485 (Communication Settings)

Mènu. 3. 3

MODBUS RS485

Mènu. 3. 3. 1

Mdbus Settings

>Baudrate: 9600 bps

Parity : No

Stop Bit : 1

Mbus ID : 1

It is the third of the 8 different setting parameters in the advanced settings menu. To change the ModBus RS485 Settings, press the SET button while the ModBus RS485 page is on the screen.

In this page, you can navigate between parameters (Baudrate, Parity, Stop Bit and ModBus ID) with the RIGHT button, and change the value in the selected parameter with the UP / DOWN buttons.

To change the current value, the relevant parameter must be selected with the RIGHT button. The selected parameter is indicated by the ">" sign on the left side.

Settings Advanced Settings Menu Operating Voltage

Mènu. 3. 4

OPERATING VOLTAGE

Mènu. 3. 4. 1

Operating Voltage
>Control : Active
High V. : 260 V
Low V. : 150 V
Delay : 5sec

Voltage(V)	Curr. (A)
L1: 220.0	L1: 380.0
L2: 220.0	L2: 380.0
L3: 220.0	L3: 380.0

ALR! Low Voltage

It is the fourth of the 8 different setting parameters in the advanced settings menu. To change the Operating Voltage Settings, press the SET button while the Operating Voltage page is on the screen.

In this page, you can navigate between the parameters (Control mode, High Voltage, Low Voltage and Delay) with the RIGHT button and change the value in the selected parameter with the UP / DOWN buttons.

To change the current value, the relevant parameter must be selected with the RIGHT button. The selected parameter is indicated by the ">" sign on the left side.

In this page, voltage control mode can be activated or deactivated, high voltage and low voltage value can be set. If the voltage rises above the set high voltage set value while the voltage control mode is active or falls below the low voltage set value, the device waits for the set delay time and then stops compensation. Then "High Voltage" or "Low Voltage" warning is displayed on the screen. Also, "ALR" contact is activated. When the voltage control mode is passive, the device does not control the voltage.

Settings Advanced Settings Menu Operating Harmonic

Mènu. 3. 5

OPERATING HARMONIC

Mènu. 3. 5. 1

Operating Harmonic
>Control : Active
THDV : 5 %
THDI : 50 %
Delay : 30sec

Voltage(V)	Curr. (A)
L1: 220.0	L1: 380.0
L2: 220.0	L2: 380.0
L3: 220.0	L3: 380.0

ALR! High THDI

It is the fifth of the 8 different setting parameters in the advanced settings menu. To change the Operating Harmonics Settings, press the SET button while the Operating Harmonics page is on the screen.

In this page, you can navigate between parameters (Control mode, Voltage Harmonic Set Value, Current Harmonic Set Value and Delay) with the RIGHT button and change the value of the selected parameter with the UP / DOWN buttons.

To change the current value, the relevant parameter must be selected with the RIGHT button. The selected parameter is indicated by the ">" sign on the left side.

In this page, voltage control mode can be activated or deactivated, voltage harmonic and current harmonic value can be set. If harmonics exceed the set values while harmonic control mode is active, the device waits for the set delay time, then stops compensation. Then "High THDI" or "High THDV" warning is displayed on the screen. Also, "ALR" contact is activated. When the harmonic control mode is passive, the device does not control the harmonics.

Menu. 3. 6

DELETE LOGS

Menu. 3. 6. 1

Delete Logs

Del /Undel

>Energy Value : Undel

Power Analys. : Undel

Ratios : Undel

It is the sixth of the 8 different setting parameters in the advanced settings menu. To enter the Delete Records menu, press the SET button while the Delete Records page is on the screen.

In this page, you can navigate between the parameters (Energy Value, Power Analysis and Ratios) with the RIGHT button, and change the value of the selected parameter with (UP / DOWN) buttons.

To change the current value, the relevant parameter must be selected with the RIGHT button. The selected parameter is indicated by the ">" sign on the left side.

Example: To delete the ratios, after entering the menu, we select the "Ratios" parameter by pressing the RIGHT button 2 times. Then we change the "Undel" option to "Del" by pressing the UP or DOWN button. Finally, when we press the SET button, all parameters marked as "Del" are deleted. If you exit the menu with ESC button without pressing the SET button, the selected parameters will not be deleted.

Menu. 3. 7

GENERATOR
SETTINGS

Menu. 3. 7. 1

Generator Settings

>Control : Active

Set : 5%

Tolerance: %4. 0

Cos: 0. 9983 Induct.

Cosinus (Cos)

L1: -0. 945 Offset

L2: 0. 145 0. 0

L3: -0. 458

GEN % R: 00 S: 00 T: 00

It is the seventh of the 8 different setting parameters in the advanced settings menu. To change the Generator Compensation Settings, press the SET button while the Generator Compensation page is on the screen.

In this page, you can navigate between the parameters (Control, Set and Tolerance) with the RIGHT button and change the value in the selected parameter with the UP / DOWN buttons.

To change the current value, the relevant parameter must be selected with the RIGHT button. The selected parameter is indicated by the ">" sign on the left side.

In this page, generator control mode can be activated or passive, generator compensation set and tolerance value can be entered. When the generator mode is activated, it compensates according to the set and tolerance value set while the generator is activated. When the generator mode is passive, compensation is stopped when the generator is activated.

NOTE: In order to use this feature, phase-neutral connection should be made to the Generator connection terminal of the device so as to energize this terminal when the generator is running.

NOTE: While the generator in the system is activated, the word "GEN" will appear on the device's screen (bottom left of the screen) as in the figure above.

Settings Advanced Settings Menu PF Correction Alarm

Menu. 3. 8

PF CORRECTI ON ALARM

Menu. 3. 8. 1

PF Correcti on Alarm
>Control : Active
I nduct. Set : 20%
Capaci t. Set : 15%
Del ay : 5 mi n

It is the last of the 8 different setting parameters in the advanced settings menu. To change the PF Correction Alarm Settings, press the SET button while the PF Correction Alarm page is on the screen.

In this page, you can navigate between the parameters (Control, Inductive Set, Capacitive Set and Delay) with the RIGHT button and change the value in the selected parameter with the UP / DOWN buttons.

To change the current value, the relevant parameter must be selected with the RIGHT button. The selected parameter is indicated by the ">" sign on the left side.

In this page, reactive / active alarm mode can be activated and can be passived, inductive / active and capacitive / active ratios can be set. When the ratios exceed the set set value, "High Inductive" or "High Capacitive" warning is displayed on the screen after the set delay time. Also, "ALR" contact is activated. When the alarm mode is passive, no warning is given.

Settings Device Settings Menu

Menu. 4. 0

DEVI CE SETTI NGS
MENU

It is the fourth menu that appears when you proceed by pressing the UP button after entering the settings page. In this menu, device settings can be returned to Factory Settings, Password can be set, Device Language and Backlight active time can be determined.

To enter the Device Settings Menu, press the SET button while the Device Settings Menu page is on the screen. Use UP and DOWN buttons to access other settings in the menu.

Settings Device Settings Menu Factory Default

Menu. 4. 1

FACTORY
DEFAULT

Menu. 4. 1. 1

Save Factory Defaul t
Are you sure?
Yes : []
No : [*]

It is the first of the 4 different setting parameters in the device settings menu. To return to factory values, press the SET button while the Factory Values page is on the screen, then select Yes and press the SET button again.

NOTE: After returning to the factory settings, it requires re-installation of the device! (Current transformer value, step values, menu settings etc. all values and records will be reset.)

Menu. 4. 2

CHANGE PASSWORD

Menu. 4. 2. 1

New Password

PASS : 0000

It is the second of the 4 different setting parameters in the device settings menu. To change the password, press the SET button while the Change Password page is on the screen.

In this page, you can navigate between the digits with the RIGHT button and change the value in the selected digit with the UP / DOWN buttons.

To change the current digit, the relevant parameter must be selected with the RIGHT button. The selected digit is indicated by the " _ " sign below it.

After setting the password value, pressing the SET button, the new password entered is saved.

Note: After changing the default password value ("0000"), the new password will need to be entered each time it is desired to enter the Settings menu.

Menu. 4. 3

LANGUAGE SETTINGS

Menu. 4. 3. 1

Choose Language

Turkce : []

Engl ish : [*]

It is the third of 4 different setting parameters in the device settings menu. To change the device language, press the SET button while the Language Option page is on the screen.

On this page, select the language you want to use as the device language by pressing the RIGHT button and there will be "*" sign next to the language you selected. After selecting the language, you can change the device language by pressing the SET button.

To exit without changing the current language option, press the ESC button to return to the Language Settings page.

Menu. 4. 4

BACKLIGHT SETTINGS

Menu. 4. 4. 1

Shutdown Time

Time : 5 min.

Backlight Time Active

It is used to reduce energy consumption and extend LCD life.

If the device is not interfered by the user during the set time (if buttons are not pressed), the LCD screen light will be turned off until the next user intervention at the end of the set time.

It is the last of the 4 different setting parameters in the device settings menu. To change the backlight off time, press the SET button while the Backlight Settings page is on the screen.

You can use UP / DOWN buttons to change the current value. Press the SET button to save.

Capacitor Calculation Table by Connection Type

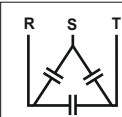
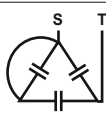
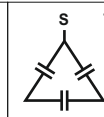
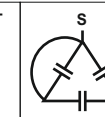
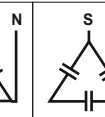
					
Capacitor Powers	3 Phase Connection (Q/3)	2 Phase Connection Bridge (Q/3)	2 Phase Connection (Q/4)	Phase-Neutral Bridge Connection (2xQ/9)	Phase-Neutral Connection (Q/6)
0,5 KVAR	0,16 KVAR	0,16 KVAR	0,12 KVAR	0,11 KVAR	0,08 KVAR
1 KVAR	0,33 KVAR	0,33 KVAR	0,25 KVAR	0,22 KVAR	0,16 KVAR
1,5 KVAR	0,5 KVAR	0,5 KVAR	0,37 KVAR	0,33 KVAR	0,25 KVAR
2,5 KVAR	0,83 KVAR	0,83 KVAR	0,62 KVAR	0,55 KVAR	0,41 KVAR
5 KVAR	1,66 KVAR	1,66 KVAR	1,25 KVAR	1,11 KVAR	0,83 KVAR
7,5 KVAR	2,5 KVAR	2,5 KVAR	1,87 KVAR	1,66 KVAR	1,25 KVAR
10 KVAR	3,33 KVAR	3,33 KVAR	2,5 KVAR	2,22 KVAR	1,66 KVAR
15 KVAR	5 KVAR	5 KVAR	3,75 KVAR	3,33 KVAR	2,5 KVAR
20 KVAR	6,66 KVAR	6,66 KVAR	5 KVAR	4,44 KVAR	3,33 KVAR
25 KVAR	8,33 KVAR	8,33 KVAR	6,25 KVAR	5,55 KVAR	4,16 KVAR
30 KVAR	10 KVAR	10 KVAR	7,5 KVAR	6,66 KVAR	5 KVAR

Step Value Determination According to Power Analysis Samples

	Table1				Table2			
	L1	L2	L3	Time (min.)	3 Phase Capacitor (kvar)	Single phase (L1) Capacitor (kvar)	Single phase (L2) Capacitor (kvar)	Single phase (L3) Capacitor (kvar)
1. Sample	0.00	0.00	1.50	571	-	-	-	1.50
2. Sample	0.00	1.00	1.50	525	-	-	1.00	1.50
3. Sample	2.00	1.50	0.50	490	1.50	1.50	1.00	-
4. Sample	0.75	1.00	1.50	470	2.50	-	0.20	0.70
5. Sample	1.50	1.80	1.00	453	3.00	0.50	0.80	-
6. Sample	0.50	2.00	2.50	400	1.50	-	1.50	2.00
7. Sample	0.20	1.50	1.90	385	0.50	-	1.30	1.70
8. Sample	0.80	0.00	0.50	350	-	0.80	-	0.50
9. Sample	0.30	0.40	0.35	300	1.00	-	0.05	-
10. Sample	2.40	3.50	4.50	295	7.50	-	1.00	2.00
11. Sample	3.20	4.00	1.50	280	5.00	1.60	2.30	-
12. Sample	2.50	4.50	1.90	257	6.00	0.50	2.5	-
13. Sample	2.70	2.90	3.20	236	8.00	-	0.20	0.40
14. Sample	0.50	1.00	1.50	205	1.50	-	0.50	1.00
15. Sample	0.00	-0.10	0.50	192	-	-	-	0.50
16. Sample	0.35	1.00	1.70	180	1.00	-	0.65	1.35
17. Sample	2.50	0.50	1.50	120	1.50	2.00	-	1.00
18. Sample	3.20	4.70	5.50	100	10.0	-	1.30	2.10
19. Sample	3.00	4.20	2.50	70	7.50	0.50	1.70	-
20. Sample	2.70	0.50	1.50	45	1.50	2.20	-	1.00

According to the power analysis examples in Table 1, the capacitor structure was created in Table 2. Intermediate values should be intervenable when creating a step structure. Connect the highest three-phase capacitor values to the first stages.

According to the table;

Three Phase capacitors have the lowest 0.5kVAr and the highest 10kVAr. **0.50kVAr, 1kVAr, 1.5kVAr, 2.5kVAr, 5kVAr ve 7.5kVAr** three-phase capacitor can be used.

The single phase capacitors to be used in the L1 phase have the lowest 0.50kVAr and the highest 2.2kVAr. **0.5kVAr, 1kVAr ve 1.5kVAr** single phase capacitor can be used.

The single phase capacitors to be used in the L2 phase have the lowest 0.20kVAr and the highest 2.3kVAr. **0.25kVAr, 0.5kVAr, 1kVAr ve 1.5kVAr** single phase capacitor can be used.

The single phase capacitors to be used in the L3 phase have the lowest 0.40kVAr and the highest 2.1kVAr. **0.25kVAr, 0.5kVAr, 1kVAr ve 1.5kVAr** single phase capacitor can be used.

Factory Defaults

Menu Name	Parameter Name	Factory Value	Min. Value	Max. Value	Unit
Current Trans. Menu	Current Transformer Value	5/5	5/5	5000/5	A
Step Time Settings	Step Drive Time	3	1	30	sec.
	Step Release Time	3	1	30	sec.
	Step Discharge Time	15	1	60	sec.
	Step Settling Time	400	100	3000	msec.
PFC Settings	PFC (A/P) Active	Active	Active	Passive	-
	TCR (A/P) Passive	Passive	Active	Passive	-
	Offset Value	0.00	-99.00	99.00	kVAr
Step Menu	Auto Step Measure. Period (A/P) Passive	0	0	26	week
Power Factor Correction Settings	Set Value	0	-50	50	%
	Tolerance Value	1.0	1.0	10.0	%
ModBus RS485 Settings	Baudrate	9600	1200	19200	bps.
	Parity	No	Even	Odd	-
	Stop Bit	1	1	2	-
	Modbus ID	1	1	247	
Operating Voltage Settings	Control Mode (A/P) Passive	Passive	Active	Passive	-
	High Voltage Value	250	240	270	V
	Low Voltage Value	180	120	210	V
	Delay Value	5	1	60	sec.
Operating Harmonic Settings	Control Mode (A/P) Passive	Passive	Active	Passive	-
	Harmonic Voltage Value	10	3	99	%
	Harmonic Current Value	50	3	99	%
	Delay Value	30	1	60	sec.
Generator Settings	Control Mode (A/P) Passive	Passive	Active	Passive	-
	Set Value	20	-50	50	%
	Tolerance Value	4.0	1.0	10.0	%
PF Correction Alarm Settings	Inductive Alarm Value (A/P) Passive	20	1	50	%
	Capacitive Alarm Value (A/P) Passive	15	1	50	%
	Delay Value (A/P) Passive	5	1	90	min.
Device Settings	Password	0000	0000	9999	-
	Backligh Shutdown Time (A/P) Active	5	1	30	min.

(A/P): It can be active or passive.

Dimensions

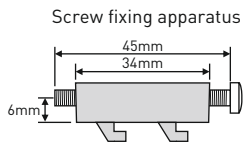
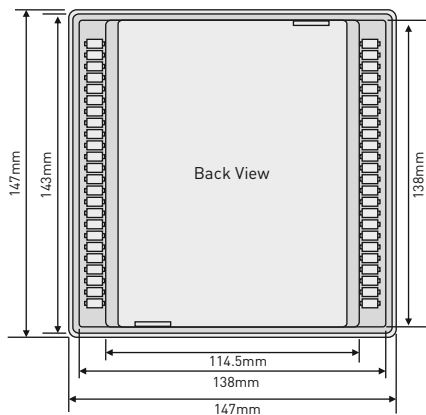
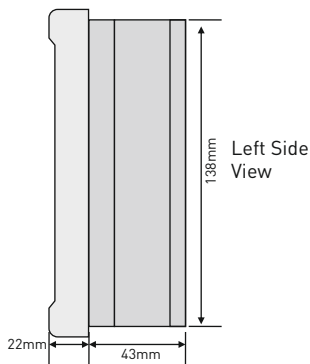
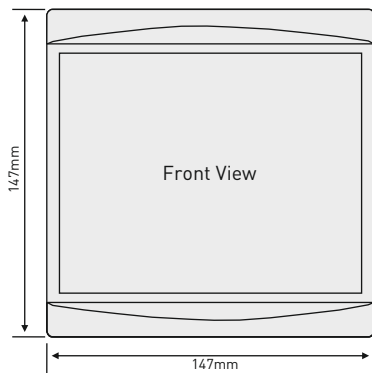

Fixing apparatus



Technical Specifications

Operating Voltage	100V - 300V AC
Operating Frequency	50/60 Hz.
Operating Power	<12VA
Operating Temperature	-20°C.....+55°C
Storage Temperature	-30°C.....+80°C
Operating Humidity	<%90
Voltage Measuring Range	5V - 300V AC
Current Measuring Range	5mA - 5,5A
Current Transformer Value	5/5A.....5000/5A
Voltage, Current Accuracy	%±0.5
Active Power Accuracy	%±1
Reactive Power Accuracy	%±2
Harmonic Voltage Measuring Range	3 - 31
Harmonic Current Measuring Range	3 - 31
Remote Communication Speed	1200, 2400, 4800, 9600, 19200bps
Remote Communication Settings	Databits.:8, Stopbits.:1, Parity:None
Remote Communication Interface	RS485 MODBUS RTU
Display	2.9" (128x64) Graphic LCD and LEDs
Connection Type	Plug-in terminal connection
Contacts	3A / 250V AC Resistive Load
Generator Input Voltage	230V AC 50/60 Hz. (Un %0,8-1,1)
Number of Stages	12 + TCR
Cable Diameter	1.5mm ² , 2.5mm ² (Voltage Inputs)
Weight	<900Gr.
Mounting	Mounting on panel front cover
Operating Altitude	<2000meters
Protection Class	IP41 (Front Panel), IP20 (Body)
Panel Hole Sizes	140mm x 140mm

Contact Informations

Web: www.tense.com.tr

Mail: info@tense.com.tr

Muratpaşa Mh., Uluyol Cd., İşkent Sanayii Sitesi, E Blok, 1. Kat,
Bayrampaşa / İstanbul / TURKEY

Tel: 0212 578 04 38 - 48 Fax: 0212 578 04 36



QUALITY SOLUTIONS

MADE IN TURKEY 

